



CARE, HANDLING, CLEANING & STERILIZATION OF INSTRUMENTS

General Care & Handling

The Catalyst CSR Shoulder Instruments are provided non-sterile and must be cleaned and sterilized prior to each use, using the following instructions.

The useable lifetime of any instrument is typically limited by normal wear and damage due to use. Instruments may be damaged by prolonged use, misuse, or improper handling. Always inspect instruments for signs of damage, cracking, wear or other signs of degradation prior to use. Do not use instruments in need of repair or replacement.

Use instruments only for the purpose for which they were designed and intended.

Use caution when handling sharp instruments to avoid injury.

All users should be qualified personnel with documented evidence of training and competency. Training should include current applicable guidelines, standards and hospital policies.

Disassembly

Most of the Catalyst CSR Shoulder Instruments are constructed in such a way that they do not require disassembly. The humeral cut guide (1226-5025), however, includes multiple parts that must be fully disassembled before decontamination. Disassemble this instrument in the operating room or central supply prior to cleaning. Assembly/disassembly instructions are provided for this instrument. While the humeral cut guide is disassembled inspect the medial cut guide for any signs of damage, cracking, or other signs of degradation that may not be apparent in the assembled device.

Cleaning

Wear protective equipment, including gloves, an apron, safety goggles and a mask. Take care with sharp instruments to avoid injuries caused by penetration or cutting. Be particularly careful when removing debris from cannulae and cavities. Wash all instruments whether or not they were used or inadvertently came into contact with blood, other body fluids or saline solution.

Do not use highly acidic (pH<4) or highly alkaline (pH>10) products for cleaning, as these can corrode metal, causing discoloration or damage.

Removal of Visible Contamination:

The effectiveness of decontamination processes depends on first removing all visible debris, tissue and bone fragments from the instruments. Thoroughly scrub and rinse instruments for at least one minute in room temperature (23°C) tap water until visibly clean prior to their initial sterilization and as soon as possible after use. If cleaning must be delayed, place groups of instruments in a covered container with an appropriate, neutral pH detergent or enzymatic cleaning solution (e.g. Enzol®), prepared according to the manufacturer's instructions, to delay drying. Do not allow soil to dry on the instruments. Remove visible soil by soaking instruments in an ultrasonic bath of the enzymatic cleaning solution for a minimum of 20 minutes at room temperature. Use a soft bristle brush to remove all visible debris, paying close attention to textured surfaces, crevices, and hard-to-reach areas. Cannulas, lumens or holes should be scrubbed for their entire length with a tight fitting, soft, non-metallic bottle brush or pipe cleaner, using an in-out and twisting motion. Use a syringe filled with cleaning solution to flush hard-to-reach areas. Instruments with moving parts should be manipulated while in the solution to expose all surfaces. Do not use metal brushes or scouring pads during the manual cleaning process.

Referencing the rinsing instructions for the enzymatic cleaning solution, rinse the instruments thoroughly with tap water for a minimum of 1 minute, flushing all cannulas, lumens and holes. Instruments with moving parts should be manipulated during the rinse to rinse all surfaces. Distilled or deionized water should be used for a final rinse for at least one minute. Dry the instruments immediately after the final rinse, removing excess moisture with a clean, absorbent, non-shedding wipe, and using compressed air to dry hard-to-reach areas. Perform a final visual inspection for cleanliness to ensure that all visible soil is removed, paying close attention to hard to reach areas. If any visible soil is noted, repeat the cleaning procedure.

Visually inspect all instruments for damage or wear and to ensure complete removal of soil prior to sterilization. Damaged instruments (including instruments that are broken, cracked, visibly corroded or discolored, and those with dulled cutting edges) must be set aside and replaced. Instruments that are not completely cleaned must be cleaned again.

Re-assembly, Assembly, Inspection, Lubrication and Wrapping

After cleaning and decontamination, disassembled instruments must be re-assembled and put in their proper locations in the instrument tray. Inspect all instruments before sterilization to ensure that they function properly. Specifically, ensure that the angled reamer (1226-5020) head spins freely after cleaning; lubricating if necessary with a nonsilicone surgical instrument lubricant compatible with steam sterilization. Lubrication, if needed, should be performed after cleaning but before sterilization. Do not include any materials incompatible with steam sterilization within the sterilization load.

Sterilization

Instruments must be completely dry before being steam sterilized. Double wrap the instrument tray using sequential wrapping techniques into a sterilization wrap, such as the BioShield Sterilization Wrap (or an equivalent wrap that is cleared for steam sterilization use by applicable regulatory bodies). **Instrument cases do not provide a sterile barrier and must be used in conjunction with a sterilization wrap to maintain sterility.**

The following parameters are recommended and have been validated for a sterility assurance level (SAL) of 10^{-6} . End users should re-validate these parameters on their own equipment to ensure that a SAL of 10^{-6} can be achieved. Flash sterilization is not recommended.

| Cycle | Temperature | Minimum Exposure Time | Minimum Drying Time |
|------------|---------------|-----------------------|---------------------|
| Pre-vacuum | 132°C (270°F) | 4 minutes | 30 minutes |

Storage

Sterile instruments should be stored in a limited access area that is well ventilated and provides protection from dust, moisture, insects and extremes in temperature and humidity.

Alternate Methods

The cleaning and sterilization instructions provided here have been validated by Catalyst OrthoScience. Other cleaning and sterilization methods may also be suitable, however, end users not using the methods recommended here are advised to validate any alternate methods using appropriate laboratory techniques.

Please contact Catalyst OrthoScience with any comments, questions or problems regarding the use or reprocessing of these products.

Humeral Cut Guide Assembly (1226-5025)

Step 1. Thread the Screw [Item 1] into the top of the Lateral Cut Guide [Item 2], but do not fully seat the screw.

Step 2. The arm of the Medial Cut Guide [Item 3] should be able to slide into the top slot of the Lateral Cut Guide [Item 2].

Step 3. Once the end of the slot in the arm of the Medial Cut Guide reaches the tip of the Screw, the Screw should be firmly tightened to secure the assembly.

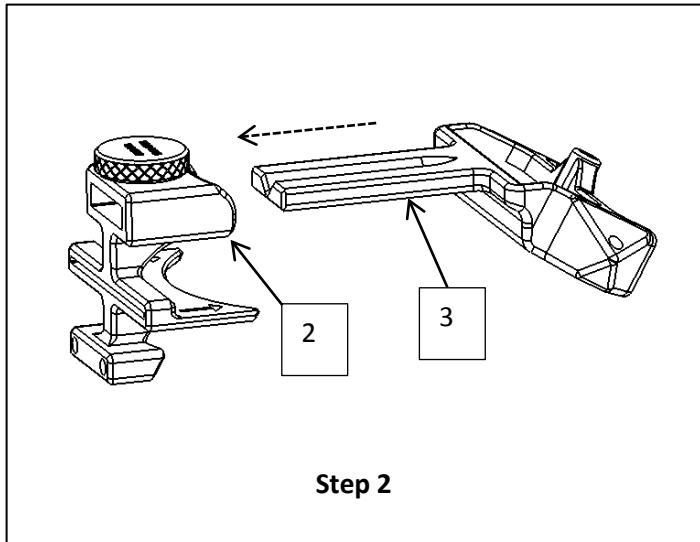
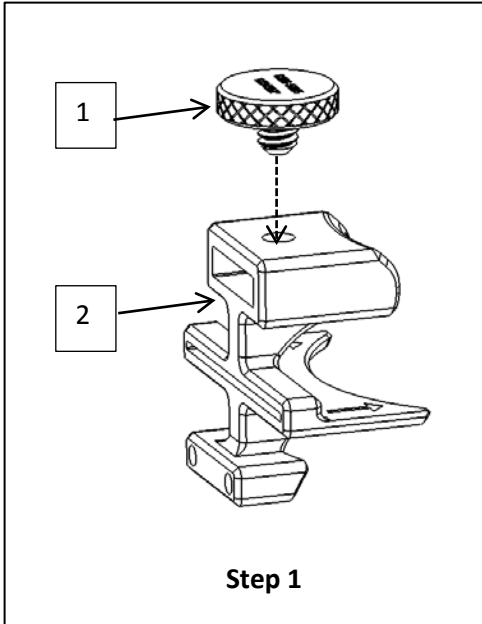

Humeral Cut Guide Disassembly (1226-5025)

Step 1. Fully unthread the Screw [Item 1] from the Lateral Cut Guide [Item 2]

Step 2. Remove the Medial Cut Guide [Item 3] from the Lateral Cut Guide [Item 2]

